



SD01A

Safety barriers



Special features

- Three optimized safety barriers for intrinsically safe installation according to ATEX for HBM transducers in potentially explosive atmospheres
- EC type examination certificate BAS01ATEX7005 (Ex II (1) GD, [EEx ia] IIC)
- For use in HBM electronics with balanced earth in carrier frequency and DC-voltage amplifiers

Dimensions of one safety barrier (in mm; 1mm=0.03937 inches)

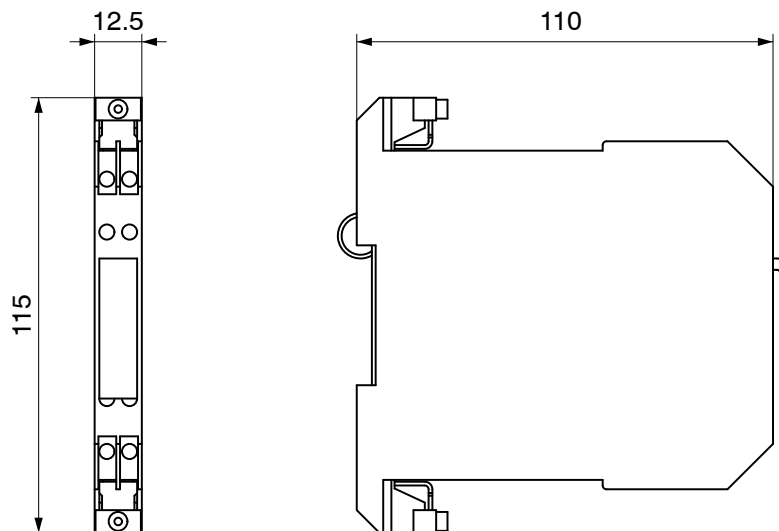

Connecting diagram

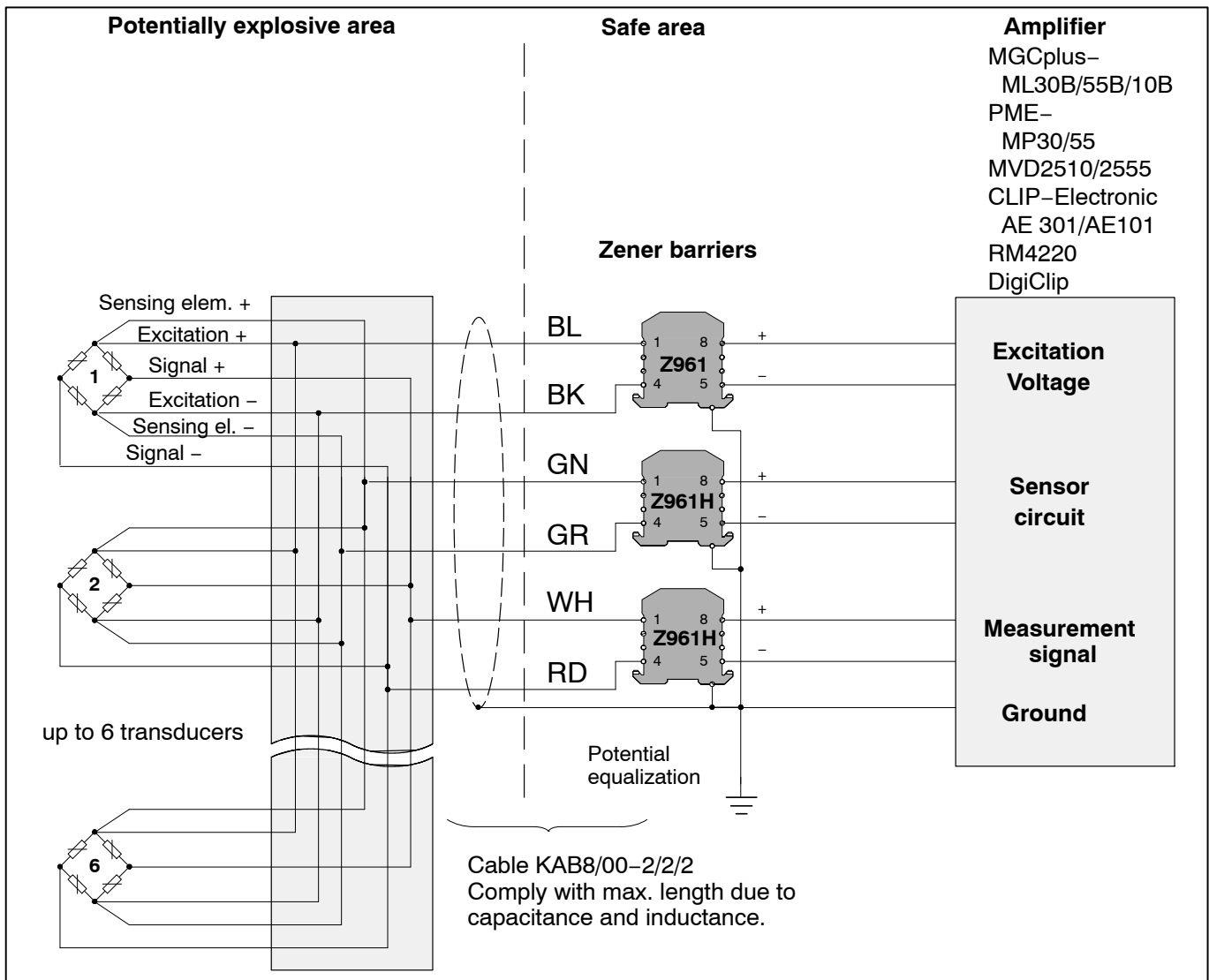

Maximum possible cable lengths:

Transducer	Excitation	Max. cable length
max. 6 x 350 Ohm	1 V CF or DC	500 m
max. 2 x 350 Ohm	2.5 V CF	500 m
3 x 350 Ohm	2.5 V CF	250 m
4 x 350 Ohm	2.5 V CF	50 m
max. 3 x 350 Ohm	2.5 V DC	500 m
4 x 350 Ohm	2.5 V DC	300 m
5 x 350 Ohm	2.5 V DC	150 m
6 x 350 Ohm	2.5 V DC	25 m
1 x 350 Ohm	5 V CF	100 m
1 x 350 Ohm	5 V DC	500 m
2 x 350 Ohm	5 V DC	100 m

For the precise layout, please refer to the operating manual.

Modifications reserved.

All details describe our products in general form only. They are not to be understood as express warranty and do not constitute any liability whatsoever.

Hottinger Baldwin Messtechnik GmbH

Im Tiefen See 45, D-64293 Darmstadt, Germany

Tel.: +49 6151 803-0 Fax: +49 6151 803 9100

Email: support@hbm.com Internet: www.hbm.com



measurement with confidence