

VKK1-4, VKK1R-4

Junction boxes



Special features

- Parallel connection of up to 4 load cells
- Off-center load compensation via integrated resistor network
- EMC-tested per EN 45 501 and EN 61 323 through HBM shielding design
- Degree of protection IP65 to EN 60 529
- VKK1R-4 with stainless housing

Dimensions (in mm; 1 mm = 0.03937 inches)
VKK1R-4

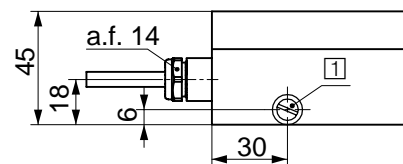
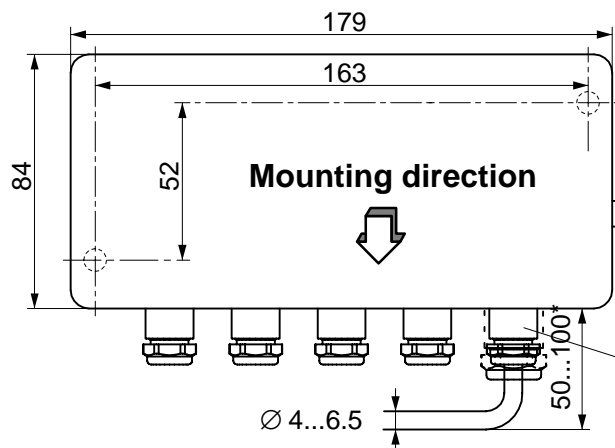

* depending on the cable type

□ Grounding screw
M5x10 DIN 84

Scope of supply includes:
1 piece of special screws for cable
diameter 7.5 mm, a.f. 17

Suitable fastening screws: M4 DIN 84 or B3.9 DIN 7971 (minimum screw length 20 mm)

Dimensions VKK1R-4 (in mm; 1 mm = 0.03937 inches)

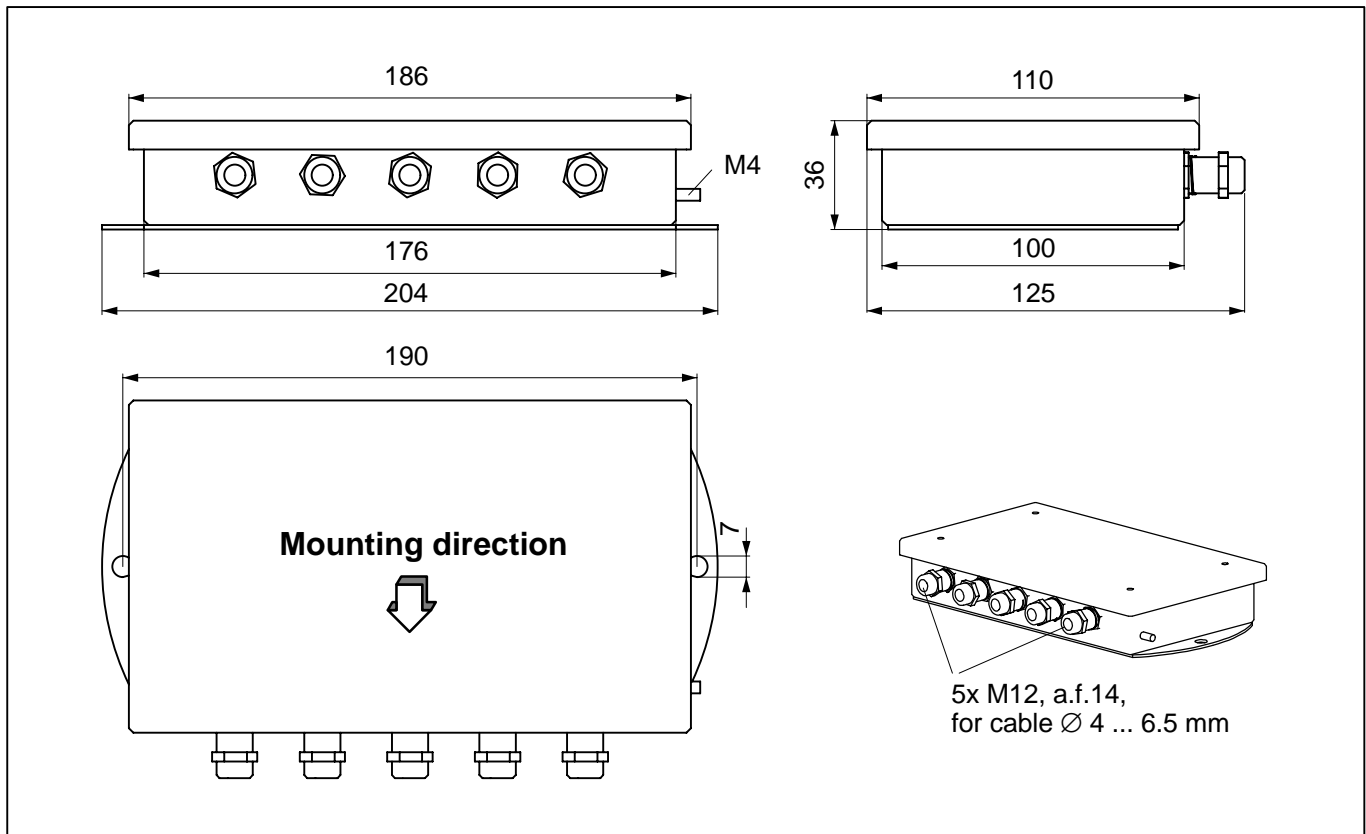

Specifications

Type		VKK1-4	VKK1R-4
Resistor network for off-center load compensation	Ω	0.39...5.71 (in 15 steps)	
Max. permissible voltage	V	18	
Nominal temperature range		-20...+85 [-4...+185]	
Operating temperature range	$^{\circ}\text{C}$ [$^{\circ}\text{F}$]	-20...+85 [-4...+185]	
Storage temperature range		-40...+85 [-40...+185]	
EMI test			
Electromagnetic field (26...1000 MHz)	V/m	10	
Burst (to connected cables)	V	1000	
Electrostatic discharge (to housing)	V	6000	
Weight, approx.	kg	1	1.5
Max. wire cross section of cable strands	mm ²	1.5	
Degree of protection according to EN 60529 (IEC 529)		IP65 (dust-tight and protected against water jets)	
Materials			
Housing		Diecast aluminum, coated (color: RAL 7001)	Stainless steel
Sleeve nut		PG7, SW14, nickel-plated brass	M12, SW14, nickel-plated brass
Clamping cone		Neoprene, for cable- \varnothing 4...6.5 mm ¹⁾	Neoprene, für cable- \varnothing 4...6.5 mm

¹⁾ Scope of supply includes: 1 piece of special screws for cable diameter 7.5 mm, a.f. 17

Resistor network in the junction box for off-center load compensation with 4 load cells

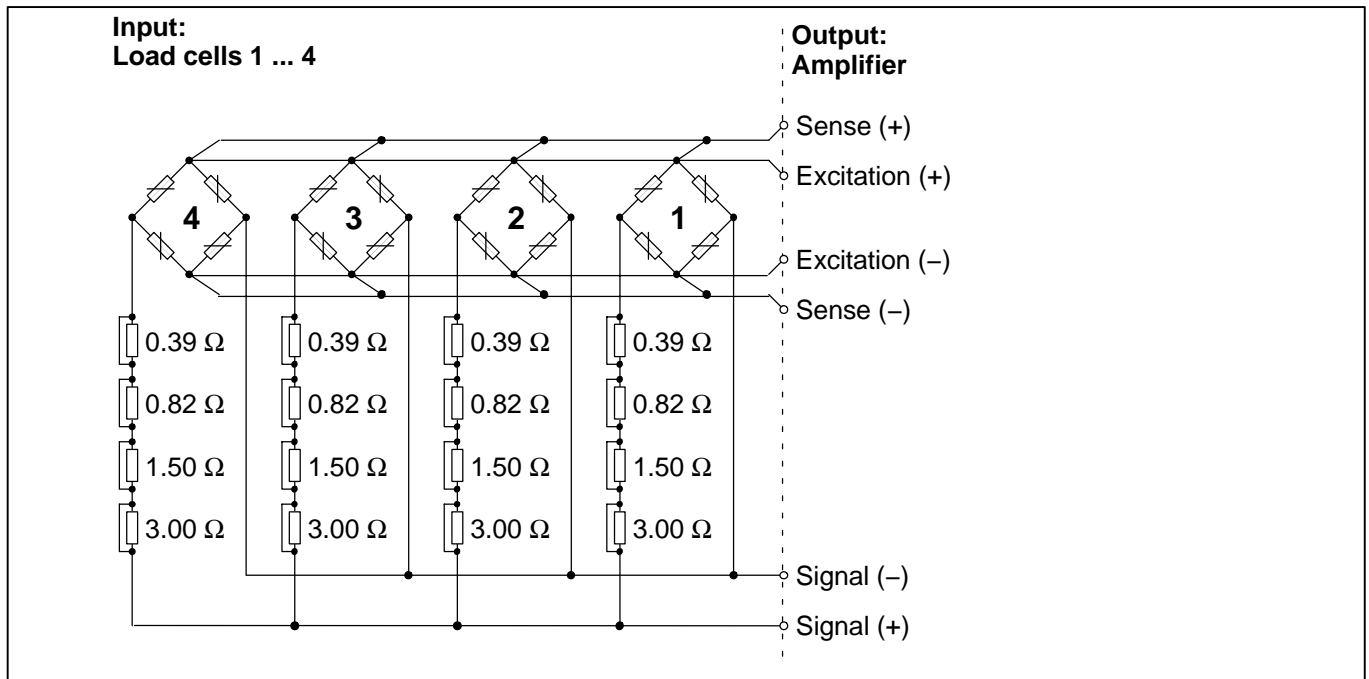







Function of the integrated resistor network

The resistor network enables off-center load compensation for a scale to be easily made, if required.

Three steps have to be taken:

1. Load scale corners.
2. Read correction value from diagram (mounting instructions).
3. Activate compensation resistor.

Survey of HBM junction boxes

	Type	Signal	Number of load cells that can be connect	Degree of protection	Housing material	EMC protection
	VKK1-4	Analog	2 ... 4	IP65	Alumin. diecast	yes
	VKK1R-4	Analog	2 ... 4	IP65	Stainless steel	yes
	VKK2-8	Analog	3 ... 8	IP65	Stainless steel	yes
	VKK2R-8	Analog	3 ... 8	IP65	Sheet steel, powder coated	yes
	VKK2R-8EX	Analog	3 ... 8	IP65	Stainless steel	yes
	VKK2R-8 DIGITAL	Digital	3 ... 8	IP65	Stainless steel	yes

Modifications reserved.

All details describe our products in general form only. They are not to be understood as express warranty and do not constitute any liability whatsoever.

B2287-1.0 en

Hottinger Baldwin Messtechnik GmbH

Im Tiefen See 45, D-64293 Darmstadt, Germany
 Tel.: +49 6151 803-0; Fax: +49 6151 8039100
 E-mail: support@hbm.com www.hbm.com



measurement with confidence